

■ Drilling and Boring

Combination Holder

Combination Holder (Collet Chuck Type)

Drilling and Boring with One Body. Machining Efficiency Increased. Number of Tools Reduced.

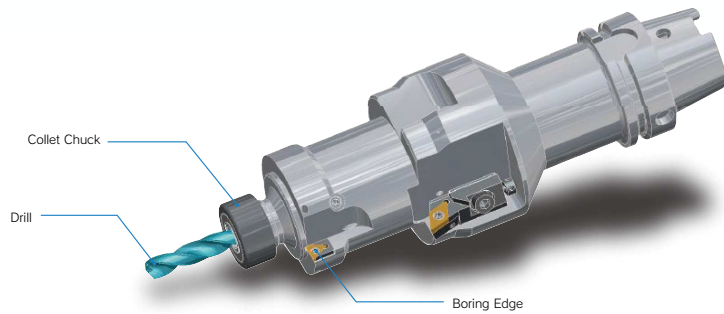

Combination Holder (Hydro Chuck Type)

For High Precision

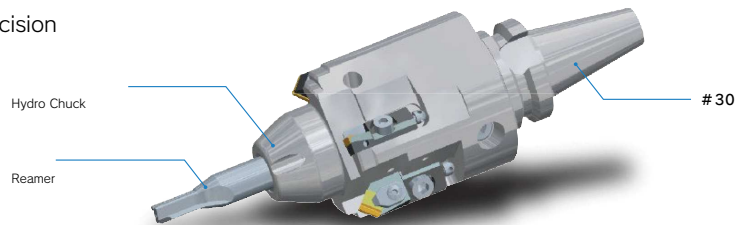

■ Example of Application

Combine for Same Axis Hole

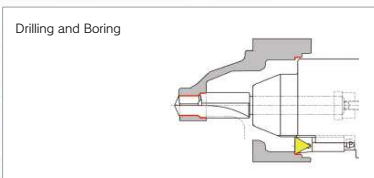

Combine for Different Axis Hole

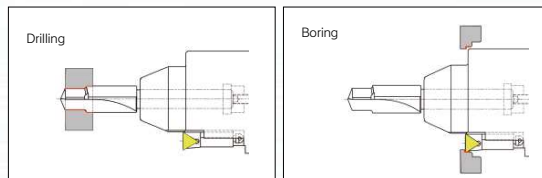

■ Matching Surface

SWM Cutter

Monolithic Steel Body Milling Cutter with Minimal Length

Special Design for #30 Machine

- 01 GL70 is made possible.
- 02 3kg up to diameter 180.
- 03 Rigidity increased by 20%.

※Compared with Aluminum Body

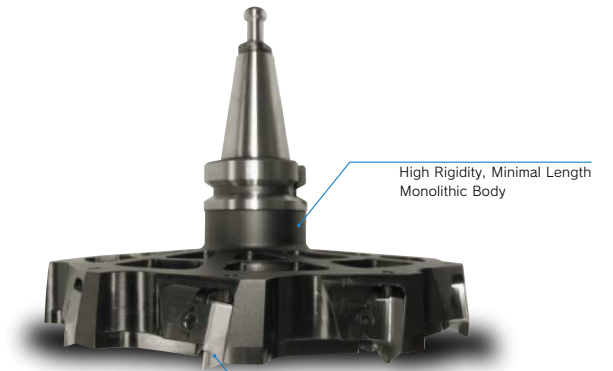
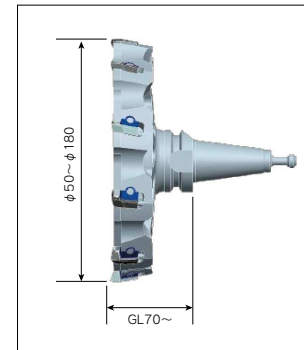

Low Cutting Force by Rake Angle
Low Cost by Resharpener

Multiple Downsized Bits



Rib Structure secures Lightweight and High Rigidity

Coolant Groove