

GB Tool

Guide-pad Boring Tool

PAT. 4759127
PAT. 4860047

High Precision Boring by Guide Pads



01 最小設定径 $\phi 16\sim$
Min.tool Dia.

01 Good circularity by self-guiding

02 加工穴サポートで直進性良好
Good straightness by supporting of machined hole

Machining Example

シリンダーヘッド
Cylinder Head

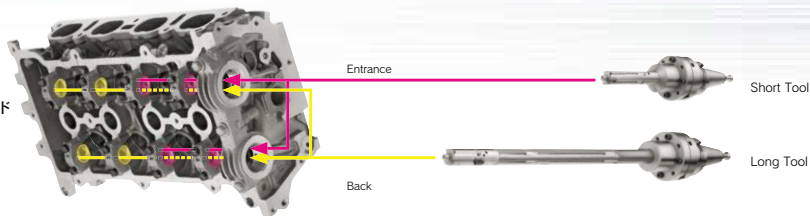

3 μm Circularity

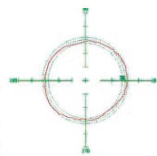

Rz3.2 Roughness

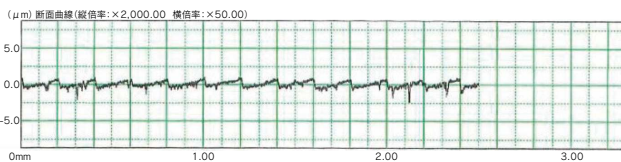

Grade IT7 Hole Dia. Accuracy

【切削条件】	切削速度 送り 内部給油 クーラント濃度	Cutting Speed Feed Rate Internal coolant Coolant concentration	200~300m/min 0.1~0.2mm/rev 5%以上
【設定参考】	シリンダーヘッドカム穴、ステアリングハウジング Cylinder Head/Cam hole, Steering Housing		

Special Angular Unit

プラスフット Plus Foot PAT.5411686

Rigidity Increased by 50%



Supported by the "Foot"

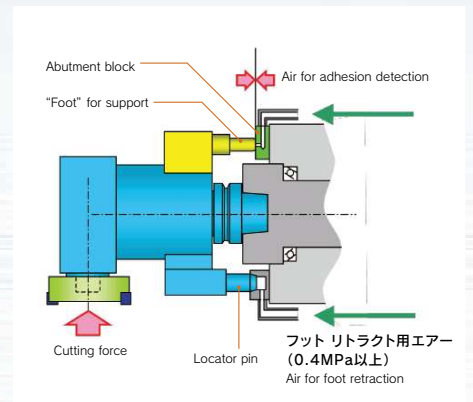

Mini Angular Head

Chamfering and deburring of small intersecting holes

